

S.NO	CATALOG NUMBER	L	W	H	CONDUCTOR SIZE	CONDUCTOR MATERIAL
1	C2-25	.56 [14]	.25 [6]	.48 [12]	#12 To #8 AWG	COPPER
2	C2-35	.88 [22]	.34 [9]	.56 [14]	#6 AWG	COPPER
3	C2-50	.88 [22]	.39 [10]	.63 [16]	#4 AWG	COPPER
4	C2-70	1.00 [25]	.50 [13]	.72 [18]	#2 AWG	COPPER
5	C2-125	1.25 [32]	.59 [15]	.88 [22]	2/0 TO 1/0 AWG	COPPER

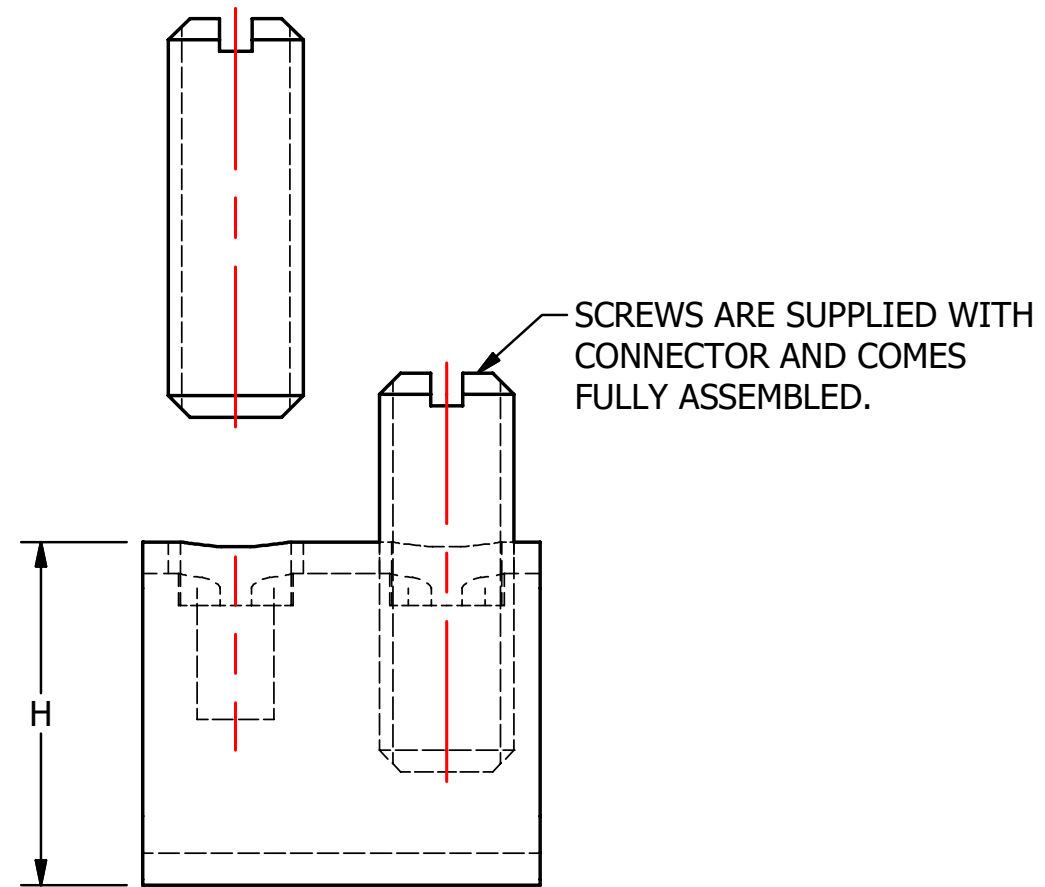

MATERIAL: COPPER
CONDUCTOR MATERIAL: COPPER

					TO ORDER CMC PRODUCTS CALL 1-513-860-4455	DRAWN BY: TS 07-16-19	NAME OF PART: COLLAR ASSEMBLY	CAT. NO.: SEE TABLE
					FOR PRODUCT INFO: http://www.cmclugs.com	CHECKED BY:	DWG NO: C00497201-S (CHARTED)	A
A	NEW DRAWING CREATED		07-16-19	TS		DRAWING NOT TO SCALE		SHEET NO: 1 OF 1
REV.	DESCRIPTION	ECN	DATE	INIT.				

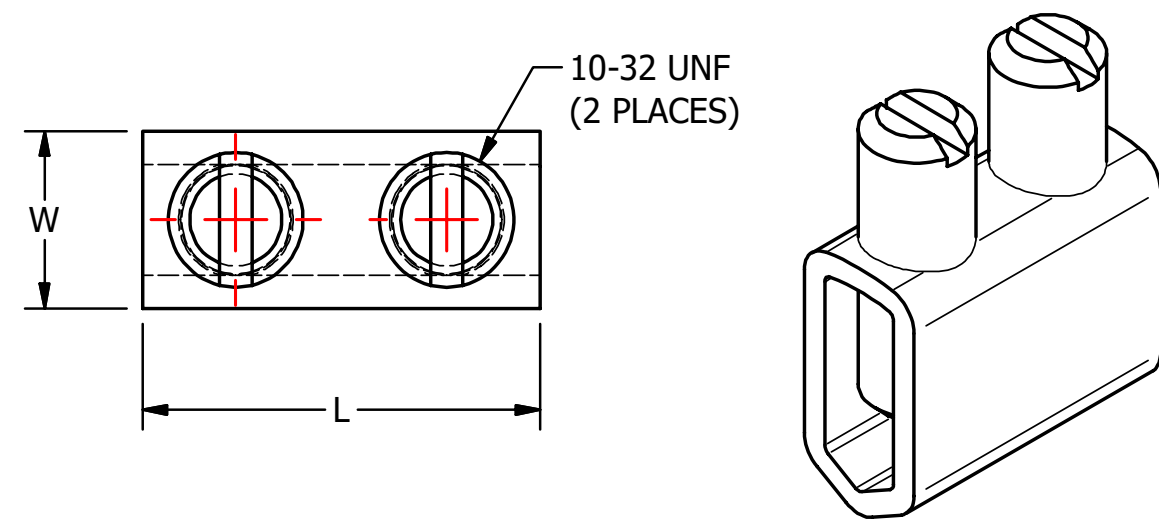